

The GigaTech Products **10GB-BX40-U-GT** is programmed to be fully compatible and functional with all intended EXTREME switching devices. This SFP module is based on the 10G Ethernet IEEE 802.3ae standard and is designed to be compliant with the SFF-8431 SFP Multi-source Agreement (MSA). This module is designed for single mode simplex fiber and operates at a nominal transmit wavelength of 1270nm and nominal receive wavelength of 1330nm up to 40KM.

Features:

- Up to 10.7Gbd bi-directional data links
- Hot-pluggable SFP+ footprint
- 1270nm DFB laser transmitter
- 1330nm APD receiver
- Simplex LC connector
- Built-in digital diagnostic function
- Up to 40km over single mode fiber
- Single power supply 3.3V
- Operating temperature range
C-Temp: 0°C to 70°C



Compliance:

- IEEE 802.3ae 10GBase-LR/LW
- MSA SFF8431
- SFP 10G FC
- RoHS Compliant

Applications:

- 10GBASE-LR/LW Ethernet
- 10GB Fiber Channel

Warranty:

GigaTech Branded Optical Transceivers- Lifetime Warranty

General Specifications

Parameter	Symbol	Min	Typ	Max	Unit	Remarks
Data Rate	<i>DR</i>		10.3125		GBd	IEEE 802.3ae
Bit Error Rate	<i>BER</i>			10 ⁻¹²		
Input Voltage	<i>V_{CC3}</i>	3	3.3	3.6	V	
Maximum Voltage	<i>V_{MAX}</i>	-0.5		4	V	Electric Power Interface
Supply Current	<i>I_S</i>		250	280	mA	Electric Power Interface
Storage Temperature	<i>T_{STO}</i>	-40		85	°C	Ambient Temperature

Link Distances

Parameter	Fiber Type	Distance Range (km)
10.3125 GBd	9/125 SMF	20km

Optical Characteristics - Transmitter

Parameter	Symbol	Min	Typ	Max	Unit	Remarks
Optical Center Wavelength	λ	1260	1270	1280	nm	
Output Optical Power	<i>P_{TX}</i>	-3		2	dBm	Average
Optical Modulation Amp	<i>OMA</i>	-5.2				Per IEEE 802.3ae
Extinction Ratio	<i>ER</i>	3	5.5		dB	
Spectral Width (-20 dB)	$\Delta\lambda$			0.6	nm	
Side Mode Suppression Ratio	<i>SMSR</i>	30			dB	
Relative Intensity Noise	<i>RIN</i>			-128	dB/Hz	
Transmitter Dispersion Penalty	<i>TDP</i>			3.2	dB	
Launch Power of OFF Transmitter	<i>P_{OUT_OFF}</i>			-30	dBm	Average
Transmitter Jitter	According to IEEE 802.3ae requirement					

Optical Characteristics - Receiver

Parameter	Symbol	Min	Typ	Max	Unit	Remarks
Optical Center Wavelength	λ_C	1320	1330	1340	nm	
Optical Input Power	<i>P_{IN}</i>	-19		0.5	dBm	Average
Receiver Sensitivity in OMA @ 10.3GBd	<i>P_{SENS1}</i>			-19	dBm	Worst ER: BER<10 ⁻¹² 2 ³¹ -1 PRBS
Receiver Reflectance	<i>TR_{RX}</i>			-12	dB	
LOS Assert	<i>LOS_A</i>	-30			dBm	
LOS De-Assert	<i>LOS_D</i>			-21	dBm	
LOS Hysteresis		0.5			dB	

Electrical Characteristics – Transmitter

<i>Parameter</i>	<i>Symbol</i>	<i>Min</i>	<i>Typ</i>	<i>Max</i>	<i>Unit</i>	<i>Remarks</i>
Input differential impedance	R_{IN}		100		Ω	Non Condensing
Single ended data input swing	V_{IN_PP}	250		800	mV	
Transmit Disable Voltage	V_D	2		V_{CC}	V	
Transmit Enable Voltage	V_{EN}	V_{EE}		$V_{EE} + 0.8$	V	

Electrical Characteristics – Receiver

<i>Parameter</i>	<i>Symbol</i>	<i>Min</i>	<i>Typ</i>	<i>Max</i>	<i>Unit</i>	<i>Remarks</i>
Differential data output swing	V_{OUT_PP}	150	300	425	mV	
Data output rise time	T_R		30		ps	20%-80%
Data output fall time	T_F		30		ps	20%-80%
LOS Fault	V_{LOS_F}	2		V_{CC_HOST}	V	
LOS Normal	V_{LOS_N}	V_{EE}		$V_{EE} + 0.5$	V	

Digital Diagnostic Functions

The SFP support the 2-wire serial communication protocol as defined in the SFF 8472. Digital diagnostic information are accessible over the 2-wire interface at the address 0xA2. Digital Diagnostics are internally calibrated by default. A micro controller unit inside the transceiver gathers the monitoring information and reports the status of transceiver.

Transceiver Temperature- Internally measured, represented as a 16 bit signed twos complement value in increments of 1/256 degrees Celsius, Temperature accuracy is better than ± 3 degrees Celsius over specified operating temperature and voltage.

Transceiver Supply Power- Internally measured, represented as a 16 bit unsigned integer with the voltage defined as the full 16 bit value (0 – 65535) with LSB equal to 100 μ Volt, yielding a total range of 0 to +6.55 Volts.

Transceiver TX bias current- Internally measured, represented as a 16 bit unsigned integer with the current defined as the full 16 bit value (0 – 65535) with LSB equal to 2 μ A, yielding a total range of 0 to 131mA. Accuracy is better than $\pm 10\%$ over specified operating temperature and voltage.

Transceiver TX output power- Internally measured, represented as a 16 bit unsigned integer with the power defined as the full 16 bit value (0 – 65535) with LSB equal to 0.1 μ W. Data is assumed to be based on measurement of laser monitor photodiode current. Accuracy is better than ± 3 dB over specified temperature and voltage. Data is not valid when the transmitter is disabled.

Transceiver RX received optical power- Internally measured, represented as a 16 bit unsigned integer with the power defined as the full 16 bit 35 value (0 – 65535) with LSB equal to 0.1 μ W. Accuracy is better than ± 3 dB over specified temperature and voltage.

<i>Parameter</i>	<i>Symbol</i>	<i>Accuracy</i>	<i>Units</i>	<i>Report Range</i>	<i>Unit</i>	<i>Remarks</i>
Temperature	T_{MON}	± 3	$^{\circ}C$	-10 - +85	$^{\circ}C$	
Voltage	V_{MON}	± 0.1	V	2.9 - 3.7	V	
Bias Current	T_F	± 10	%	1 – 15	mA	
Tx Power	V_{LOS_F}	± 3	dB	-10 – +10	dBm	
Rx Power	V_{LOS_N}	± 3	dB	-20 – +5	dBm	

Block Diagram of Transceiver

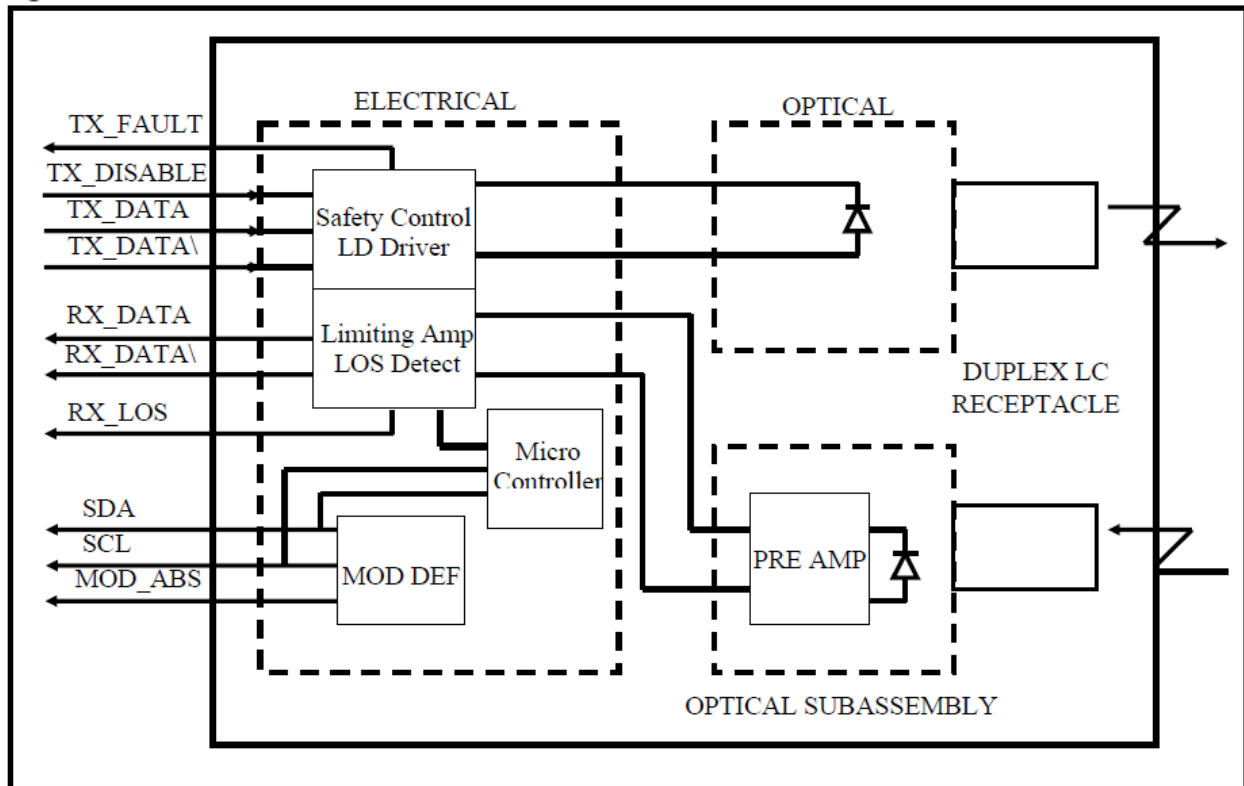

Transmitter Section- The Laser driver accept differential input data and provide bias and modulation currents for driving a laser. An automatic power-control (APC) feedback loop is incorporated to maintain a constant average optical power. 1270 DFB in an eye safe optical subassembly (OSA) mates to the fiber cable.

TX_DISABLE- The TX_DISABLE signal is high (TTL logic "1") to turn off the laser output. The laser will turn on within 1ms when TX_DISABLE is low (TTL logic "0").

TX_FAULT- When the TX_FAULT signal is high, output indicates a laser fault of some kind. Low indicates normal operation.

Receiver Section- The receiver utilizes a PIN detector integrated with a trans-impedance preamplifier in an OSA. This OSA is connected to a Limiting Amplifier which providing post-amplification quantization, and optical signal detection. The limiting Amplifier is AC-coupled to the transimpedance amplifier, with internal 100Ω differential termination.

Receive Loss (RX_LOS)- The RX_LOS is high (logic "1") when there is no incoming light from the companion transceiver. This signal is normally used by the system for the diagnostic purpose. The signal is operated in TTL level.

Controller Section- The micro controller unit monitors the operation information of LD driver and Limiting Amplifier and report these status to the customer.

Dimensions

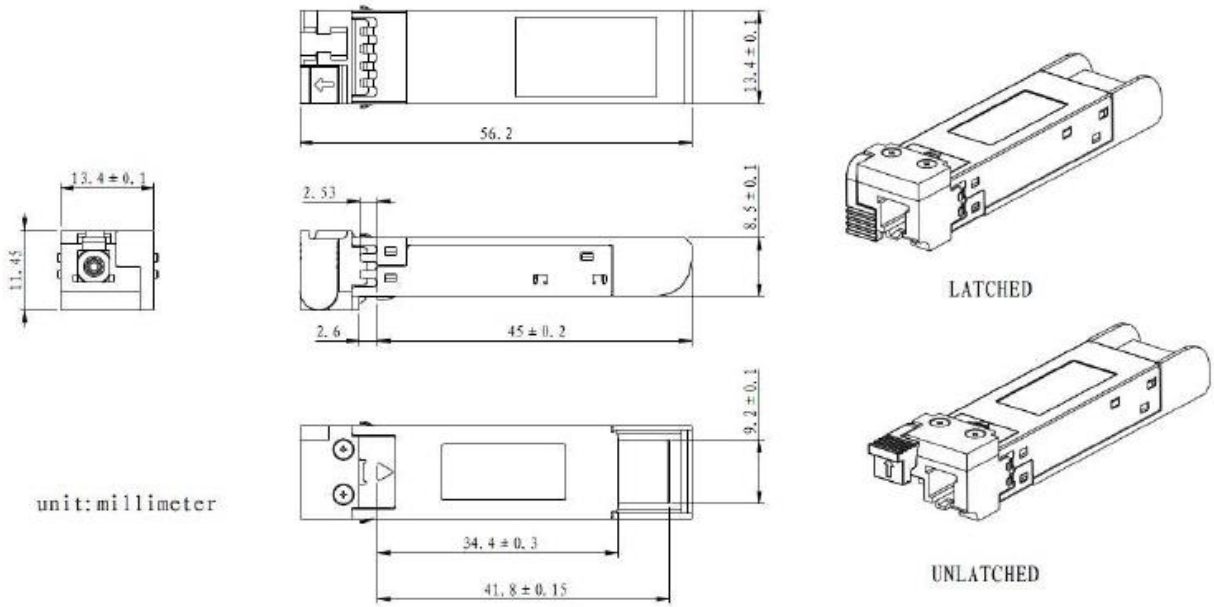

ALL DIMENSIONS ARE ±0.2mm UNLESS OTHERWISE SPECIFIED UNIT: mm

PCB Layout Recommendation

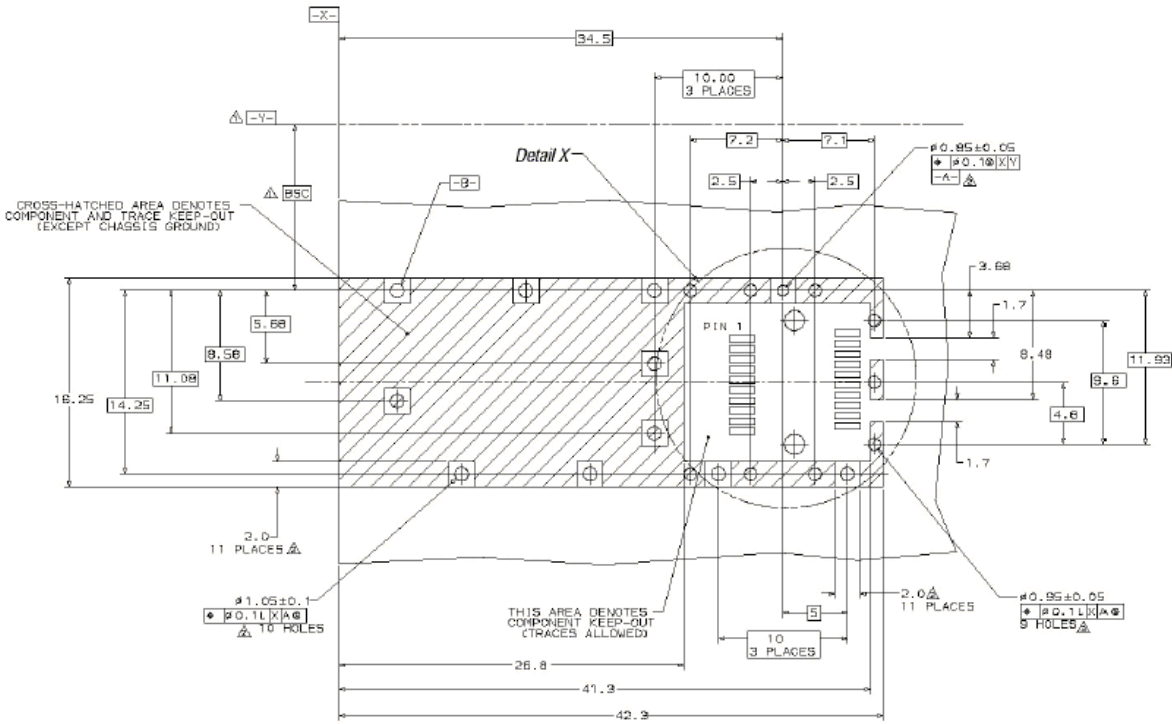

Δ Datum and Basic Dimension Established by Customer

Δ Rads and Vias are Chassis Ground, 11 Places

Δ Through Holes are Unplated

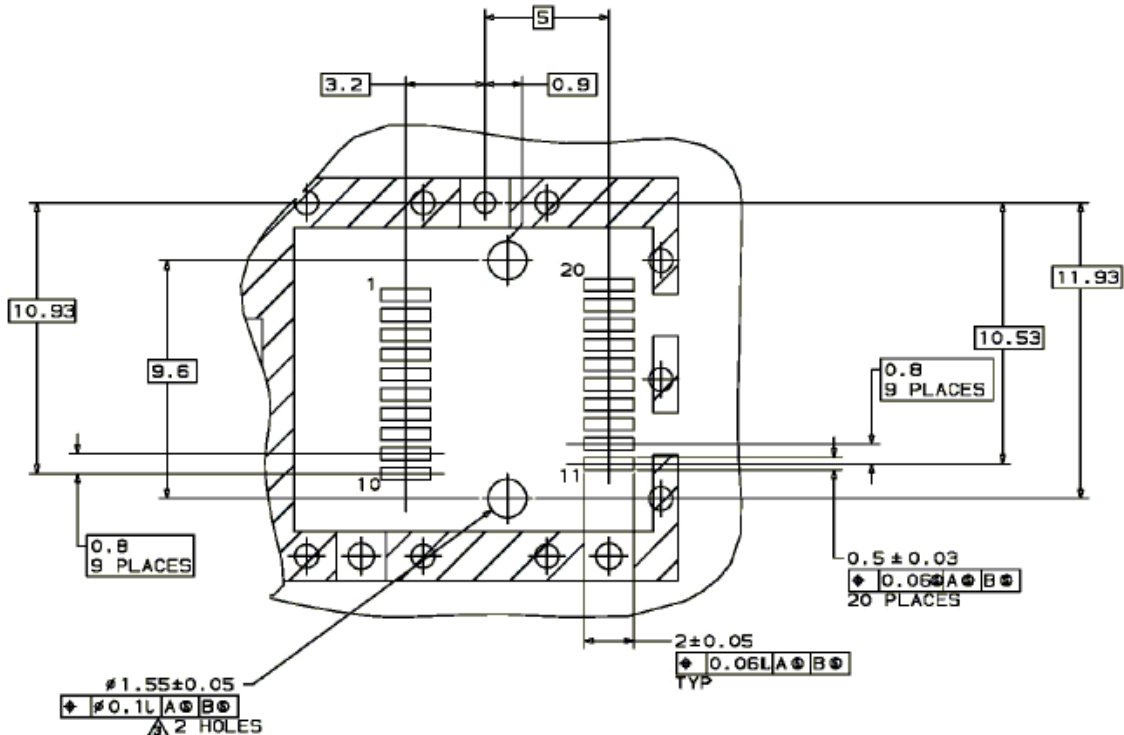

Electrical Pad Layout

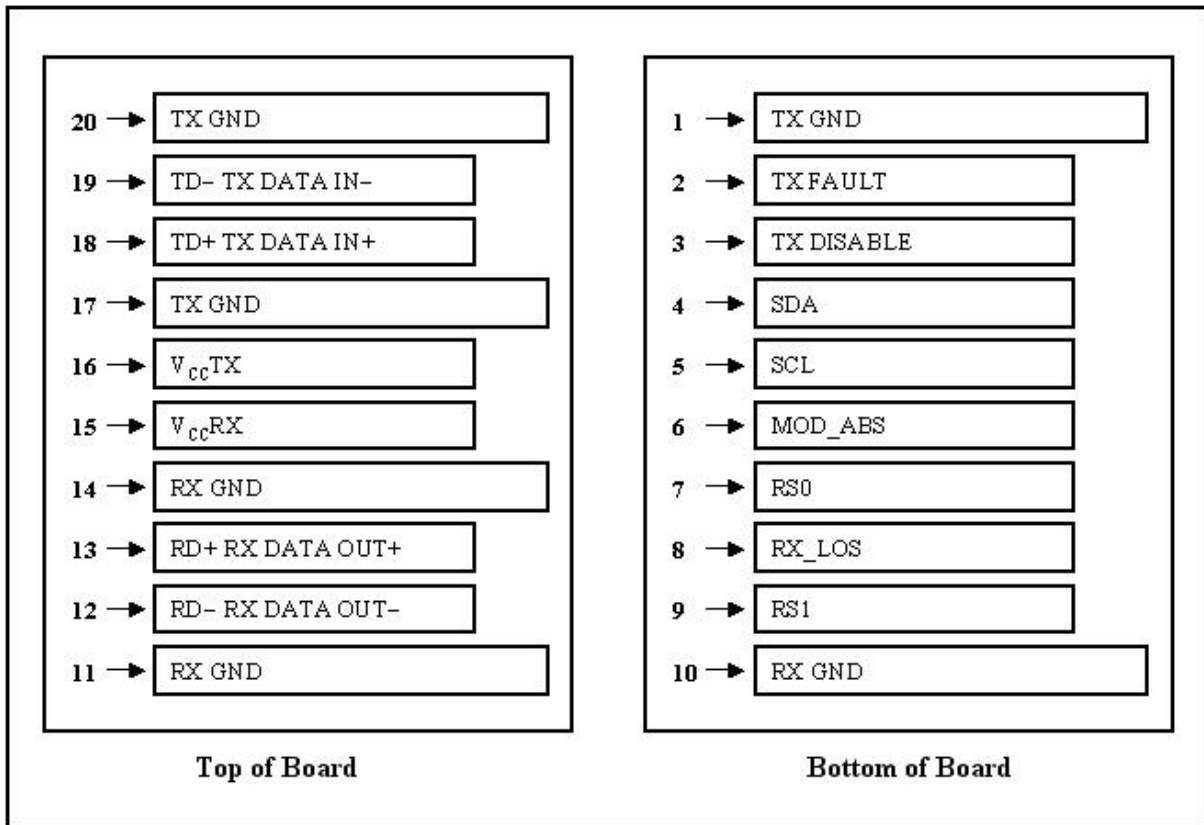
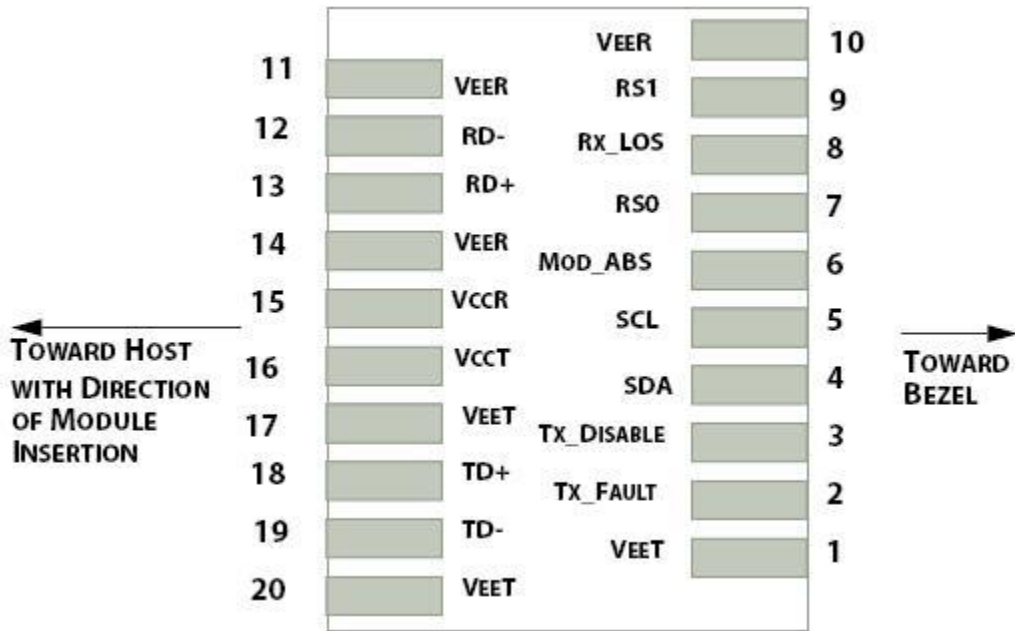

Pin Assignment

PIN #	Symbol	Description	Remarks
1	VEET	Transmitter ground (common with receiver ground)	Circuit ground is isolated from chassis ground
2	TFAULT	Transmitter Fault	
3	TDIS	Transmitter Disable. Laser output disable on high or open	Disabled: TDIS>2V or open Enabled: TDIS<0.8V
4	SDA	Data line for serial ID	Should Be pulled up with 4.7k – 10k ohm on host board to a voltage between 2V and 3.6V
5	SCL	Clock line for serial ID	
6	MOD_ABS	Module Absent. Ground within the module	
7	RS0	No Connection required	
8	LOS	Loss of Signal indication. Logic 0 indicates normal operation	LOS is open collector output
9	RS1	+3.3V Power Supply	Circuit ground is isolated from chassis ground
10	VEER	Receiver ground (common with transmitter ground)	
11	VEER	Receiver ground (common with transmitter ground)	
12	RD-	Receiver Inverted DATA out. AC coupled	
13	RD+	Receiver Non-inverted DATA out. AC coupled	
14	VEER	Receiver ground (common with transmitter ground)	Circuit ground is isolated from chassis ground
15	VCCR	Receiver power supply	
16	VCCT	Transmitter power supply	Same as Pin# 1
17	VEET	Transmitter ground (common with receiver ground)	Circuit ground is connected to chassis ground
18	TD+	Transmitter Non-inverted DATA out. AC coupled	
19	TD-	Transmitter Inverted DATA out. AC coupled	
20	VEET	Transmitter ground (common with receiver ground)	Circuit ground is connected to chassis ground

References

1. IEEE standard 802.3ae. IEEE Standard Department, 2005.
2. Enhanced 8.5 and 10 Gigabit Small Form Factor Pluggable Module “SFP+” – SFF-8431
3. Digital Diagnostics Monitoring Interface for Optical Transceivers – SFF-8472.